Global Communications Newsletter

October 2005

Technical Report on SoftCOM 2004 Conference on Software, Telecommunications, and Computer Networks

By Hrvoje Dujmic, Dinko Begusic, and Nikola Rozic, University of Split, Croatia

The 12th International Conference on Software, Telecommunications, and Computer Networks SoftCOM 2004 was held from 10 to 13 October 2004 in the pleasant ambience of the cruise ship *Marko Polo* on the attractive route Split-Dubrovnik-Split-Venice-Split. It was organized by the University of Split, Faculty of Electrical Engineering, Mechanical Engineering and Naval Architecture, Croatian Communication and Information Society (CCIS), the IEEE ComSoc Sister Society, under the auspices of the Central State Administrative Office for e-Croatia of the Government of the Republic of Croatia, the Ministry of Science, Education and Sports, and the Ministry of the Sea, Tourism, Transport and Development with principal patron T-Croatian Telecom. The Conference was technically co-sponsored by the IEEE Communications Society (ComSoc), Technical Committees of Communications Software and of Multimedia Systems.

Researchers and experts from industry, research institutes, and universities from more than 40 countries all around the world submitted in total 203 papers for presentation at SoftCOM '04. Submitted papers were reviewed by more than 100 scientists from universities, institutes, and companies all over the world. All accepted papers were carefully selected based on their contribution, relevance, conceptual clarity, and overall quality. Nearly 69 percent of submitted papers were recommended for presentation within the technical program.

Accepted and presented papers were published in the Conference proceedings. Authors of selected papers have been invited to submit extended versions of their manuscripts for publication in the first issue of the *Journal of Communications Software and Systems* (COMSS), which will be launched by the CCIS in cooperation with the University of Split in July 2005.

The conference program featured a symposium dedicated to the most timely topics in the area of mobile and wireless communications. Two special sessions and 17 general conference sessions, a poster session, and two professional workshops (one dedicated to the wide spectra of themes in the area of ICT, the other dedicated to signals and systems in human motion) were held too. In addition, five half-day tutorials were held: "QoS in the Next Generation Networks and Wireless Networks" by P. Lorenz, Université de Haute Alsace; "Challenges in High Performance Network Monitoring" by F. Risso, Politecnico di Torino; "Tools for Teaching Network Planning" by A. Pakstas, London Metropolitan University; "Advanced Wireless: WiFi and Beyond" by J. Mollenaar, Technical Strategy Associates, and "The Computer and the Brain" by G.W. Luderer, Arizona State University.

The keynote speech, "eEurope and e-Croatia: Information and Technology Integration," was presented by M. Kovacic, Central State Administrative Office for e-Croatia of the Gov-

ernment of the Republic of Croatia. R. Saracco from Telecom Italia presented an invited talk, "Technology Evolution in ICT: Biz Challenges and Opportunities," and B. Soucek presented a talk on the topic "Consciousness and Software."

In conjunction with SoftCOM '04, a Business Forum has been organized featuring invited talks, round tables, and presentations with participation of managers, executives, experts, and government and institution representatives who discussed and exchanged opinions and experiences on a number of hot topics in the contemporary and future ICT industry and market including business, technological, and social aspects. In addition, prototype demonstrations as well as exhibits were held in the area of the car deck of the ship.

The fruitful collaboration with universities from Ancona, Lecce, Bari, Budapest, Zagreb, and London has contributed to the quality of the Program significantly.

The 13th International Conference on Software, Telecommunications, and Computer Networks (SoftCOM 2005), technically co-sponsored by ComSoc, was held 15–17 September in Split, Croatia. Split is a golden spot on the Croatian Adriatic coast, the starting point for the most beautiful touristic destinations. Split is the business, political, and university regional center, a 1700-year-old town with the Diocletian Palace monument. More information about SoftCOM 2004 and 2005 conferences can be found at <http://www.fesb.hr/SoftCOM>

2005 Global Mobile Congress, Oct. 10-12 Defining China's Future Mobile Communication Technologies

By Willie W. Lu, Special Advisor of C3G/C4G Mission

The China Ministry of Information Industry, Delsion Group Worldwide, China Institute of Communications, Chongqing University of Posts & Telecommunications, IEEE China, China Mobile Communications Association, TD-SCDMA Forum, and other groups announced a very important 2005 Global Mobile Congress, Chongqing, China, which is an official governmental and technical event co-sponsored and supported by Tsinghua University, BUPT, Southeast University, Zhejiang University, Shanghai Jiaotong University, Xi'dian University, Ministry of Science and Technology, and other organizations as well as major wireless companies in China (China Mobile, Intel, Alcatel Shanghai Bell, TI, etc.) and many government authorities in wireless and mobile communications.

There has been tremendous interest recently in China's huge wireless markets and business opportunities. By 2010, China's wireless mobile markets will be over \$200 billion. In

(Continued on page 4)

From "Computer Networks" to the "Computer on Net"

The Convergence of Internet, Broadband, and Telephone Networks in the IEEE 802 Standards

By Jose Morales Barroso, L&M Data Communications

In the near future, end users, corporations, telecommunications carriers, and vendors will need a way to turn the current network technologies into something much faster, less costly, with more capabilities and integrated services over a shared unique network infrastructure. Nevertheless, if communications networks are always developed based exclusively on technology, there is a danger that they will keep getting more and more complicated.

As stated by E. F. Schumacher in his famous book *Small Is Beautiful* (1973): "Any third-rate engineer or researcher can increase complexity; but it takes a certain flair of real insight to make things simple again." We have to apply the scientific method in order to make things simpler and at the same time more efficient. Nowadays, almost everybody agrees that the future of the networks is based on "everything over IP"; however, we should ask ourselves if this future could rather be based on IEEE Ethernet.

To reduce the "digital divide," the best solution is to seamlessly develop the existing telephone network, because, as Sean Maloney, Executive Vice President of Intel, said in spring 2004, "There isn't the money in the industry to roll out fiber to a billion people's homes." This means that the current 1.25 billion fixed telephone lines all over the world must be reused, with an integrated solution in which emergency call service is supported.

The solution must also support the 3 billion mobile phone

subscribers, as well as others that use fiber optics, Wi-Fi/WiMAX, power line communications, or cable modems to access the network. Packet switching is essential for any interactive connectivity, and as the Internet model has demonstrated, complexity should only be found at the extremes of the network, maintaining the core as simple as possible without compromising performance.

The Reference Model: Applying the Concepts of Ethernet and Internet

There are two clear reference models in today's communications networks: Robert M. Metcalfe's Ethernet and Vinton G. Cerf's Internet. Those, along with the experience gained from the traditional telephone network, serve as grounds for the proposal of a new model we call the Universal Ethernet Telecommunications Service (UETS). It is 100 percent in accordance with the IEEE 802, 802.2, and 802.3 standards.

Since its invention by Robert M. Metcalfe in 1973, Ethernet has achieved widespread use. The price-performance ratio, or cost per bit transmitted, is better in Ethernet than in any other technology. Ethernet is also the most mature, flexible, scalable, and robust solution available in the market. In addition, Ethernet has the advantage of being an international IEEE 802.3 standard.

Dr. Metcalfe describes Ethernet as "a communication sys-

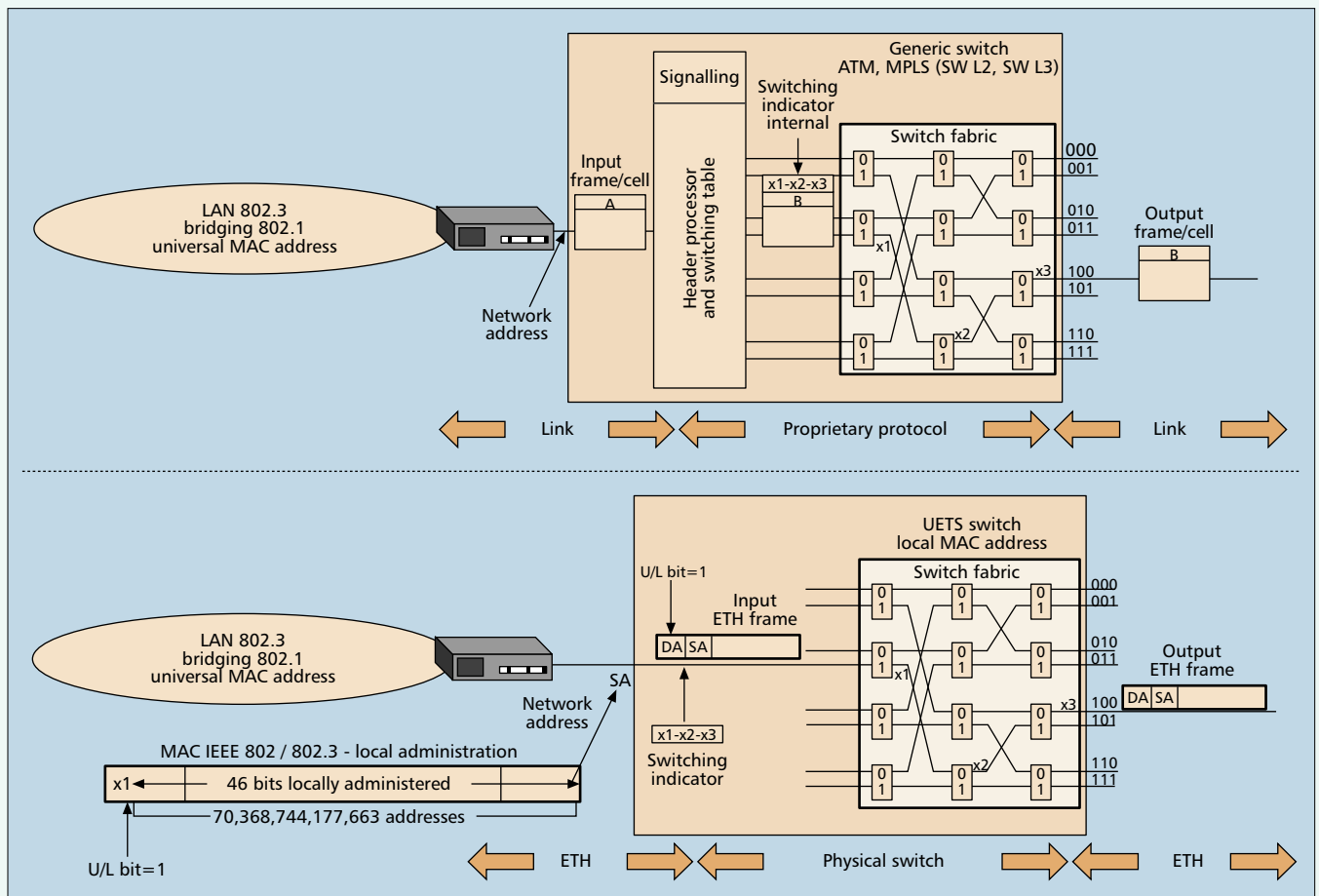
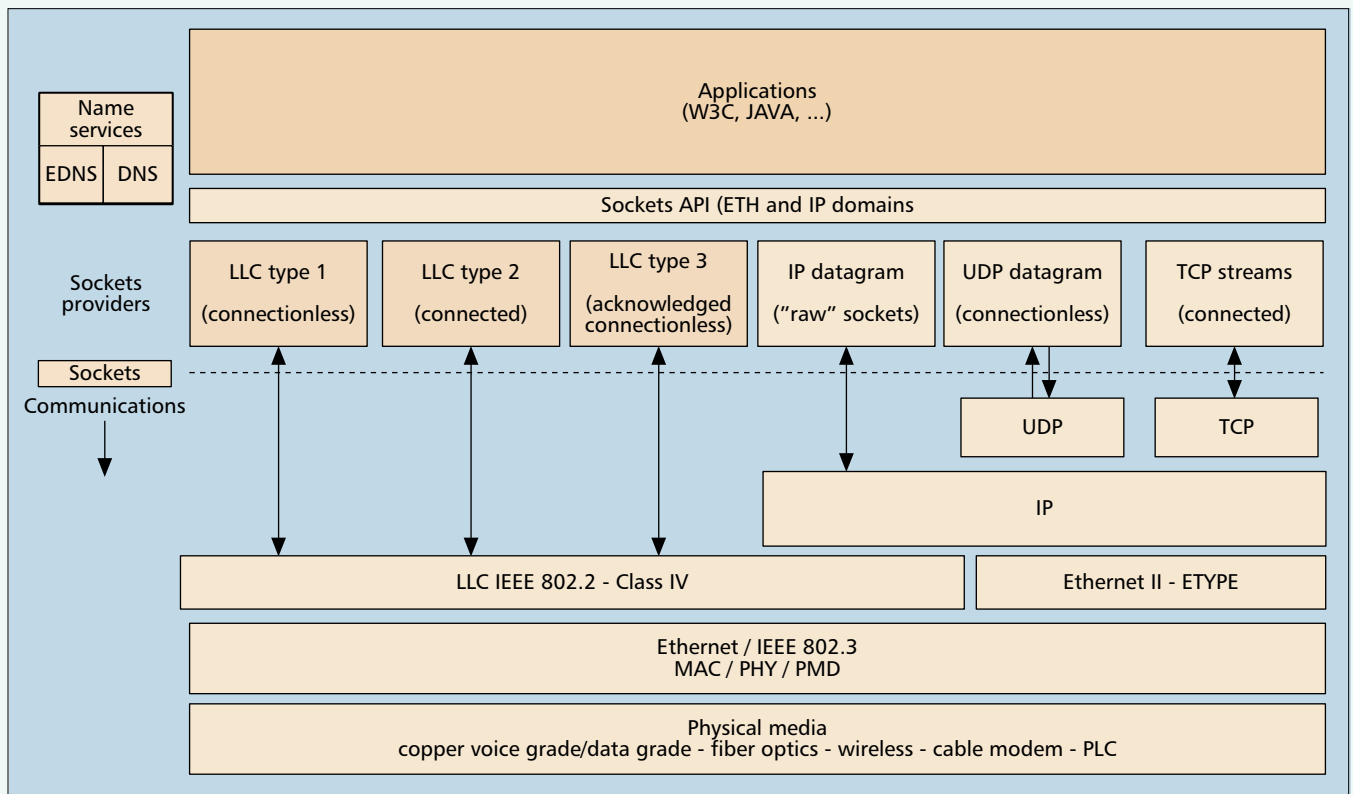

Figure 1. UETS switch: CUE (central universal Ethernet).

From “Computer Networks” to the “Computer on Net” (cont’d)



■ Figure 2. UETS communications architecture: reference model.

tem for carrying digital data packets ... to build systems, which can be viewed as ... loosely coupled multiprocessors. An Ethernet’s shared communication facility, its Ether, is a ... medium with no central control. Switching of packets to their destinations on the Ether is distributed ... using packet address recognition.”

The Internet is based on the concept of catenet, a “confederation of cooperating nets,” as Vinton Cerf describes it in IEN 48. With Robert Kahn, Cerf developed in 1973 TCP, “to interconnect these networks in such a way... that would allow many such networks to interwork and the computers on each of them to interwork.” Kahn and Cerf describe the communications between processes: “Within each host, we assume that there exist processes which must communicate with processes in their own or other hosts.”

Kahn and Cerf introduce “the notion of ports in order to permit a process to distinguish between multiple message streams,” and define what they call a uniform addressing scheme. They stress simplicity by stating “both economic and technical considerations lead us to prefer that the interface be as simple and reliable as possible.” The intelligence resides outside of the network, in the hosts connected to many physical networks that form a unique logical IP network.

The Universal Ethernet Telecommunications Service

The network model has changed since the approval of the IEEE 802.3ah EFM standard for Ethernet-based access to telecommunications networks. The UETS extends today’s local computer networks to a metropolitan or even planetary scale, and builds on the concept of Ethernet.

The key of the system, as described in Fig. 1, is to utilize physical switching techniques, like those used in asynchronous transfer mode (ATM), with the local (U/L bit = 1) MAC address of the Ethernet frames as network addressing. This

mechanism makes it possible to switch to more than 70 trillion addresses in each local Ethernet domain — enough to build a planetary network.

This opens the world to a new approach to the digital revolution, radically simplifying the operation of switching devices. It is 100 percent compliant with IEEE 802, 802.2, and 802.3 standards, has the power of ATM switches, and is cost effective and not complex. UETS network nodes can be built using the switch fabrics of current 802.1 bridges, layer 3 switches, IP routers, or ATM switches. Using the <port id> as a switching indicator in the local medium access control (MAC) address, this eliminates the internal tables.

The core of that network can use multiprotocol label switching (MPLS) techniques. With Ethernet encapsulation, which is per se multiprotocol, and the local MAC address as an end-to-end label, this particular mode of operation can be called Ethernet label switching (ELS).

Internet Applications over IEEE 802.2 LLC/802.3 Ethernet

This new paradigm of a global network, or Inthernet as we call it, is based on the idea of developing the Internet model in a way that would drastically reduce the TCP/IP processing overhead. It reduces the open system interconnection (OSI) layers so that instead of layers 3 (IP) and 4 (TCP), only layer 2 (ETH/LLC) would be used for multiprotocol transport, multiplexing, flow control, error detection, source/destination port identification, and so on.

The TCP/IP Internet is composed of a logical network (IP) over multiple physical networks (ETH, FRL, ATM, SONET/SDH). In the new UETS-based Inthernet the logical and physical networks coincide. Actually, TCP/IP hosts do not

(Continued on next page)

COMPUTER ON NET/(cont'd from page 3)

use logical IP addresses in Ethernet domains, but physical MAC addresses, obtained by means of the Address Resolution Protocol (ARP).

Ethernet also offers seamless interoperability and adaptation to changing requirements. Ethernet and IP share a set of characteristics that are of fundamental importance. Both operate in connectionless mode, and both are packet-based technologies designed for computer communications, providing statistical multiplexing needed to share network resources. However, the services provided by IP over the Internet are the same as those provided by Ethernet over just one network.

Figure 2 describes the ability to provide the same services using a layer 2 hardware-based operation device, breaking the limits of hosts collapsed by very-high-speed TCP/IP connections (see "TCP Onloading for Data Center Servers," *Computer*, November 2004, pp. 48–58). The logical link control (LLC) is better than TCP/UDP for offering end-to-end services, because it is optimized to hardware operation, and also has reduced overhead and tighter loop control.

Conclusions

This new approach can be considered the evolution from computer networks to computer on net. It keeps the original idea and "spirit" of Ethernet and Internet, extending the system of loosely coupled multiprocessors worldwide. According to George Gilder, "When the network is as fast as the computer's internal links, the machine becomes a special purpose appliance across the Internet."

The new architecture and simplification of the service, along with voice over packets (VoP), make the convergence of Internet, broadband, and telephone networks possible. It works like the traditional telephone network, but using IEEE

802.2/802.3 frames that support the higher OSI layers. Therefore, it maintains backward compatibility for Internet applications, using either TCP/IP or LLC/ETH protocols.

The new model solves the IP insecurity problems, because it is impossible to spoof addresses within the Ethernet domain. Telecommunications carriers have the additional advantage that the new architecture can use a similar addressing schema as the international telephone network, thus drastically reducing the use of domain name services.

GLOBAL MOBILE CONGRESS/(cont'd from page 1)

China you can find any advanced wireless mobile systems in the world, and over 100 world-class industrial R&D centers have moved to China to better serve this emerging market.

The Global Mobile Congress (GMC) mission was established in 2004 to foster worldwide collaboration for R&D in the next-generation wireless and mobile communication technologies, and to construct the international research platform for the promotion of educational and technological advancement of information and communication technology in China as well as the East Asia region. The GMC objective is to help define China's future mobile communications technologies, standards, and policies to meet the rapidly growing market need of the region. The GMC event circulates every year among major cities of China to reflect the timely government strategy and the business focus of the industry.

In support of the Chinese government's West Development strategy, GMC 2005 was grandly celebrated in Chongqing, the largest western city directly administrated by the central government in Beijing. Chongqing is one of the bases of China-developed time-division space-code-division multiple access (TD-SCDMA) third-generation (3G) mobile technology, and is also well-known for the world-class three gorges (3-G) project. So many people call Chongqing "Double 3G City."

China, with more than 360 million mobile subscribers, is not only a big country of mobile telecommunications in the world, but also provide the world a fast growing market for mobile telecommunications: just in the first seven months this year, more than 33 million new subscribers entered the market. With a 28 percent penetration rate, China still has great potential for further development, especially in the vast western part of the country. Here in Chongqing, you can feel the rapid "rising up" of the western area of China and see a new arena of mobile telecom technology. China has also become a very active place for mobile telecommunications R&D. The intensive R&D activities and not only engaged by major Chinese universities and companies, but also cooperated closely with foreign academic and industrial partners. As the Chinese mobile network service is going to turn to 3G, researchers are strongly addressing to the system beyond 3G or 4G.

Therefore, the Chinese government takes GMC 2005 very seriously as supporting its long-term development strategy for wireless and mobile communication industry. The focused topics of GMC 2005 are: China's 3G rollout strategy; Mission 2020 R&D Plan (4G Plan) for future wireless mobile communications technology; and secured networks and systems for the Beijing Olympic Games. Besides, GMC 2005 also covers emerging issues such as 3G licensing results, new strategies on converged broadband wireless China, reorganizing service providers and operators, new telecom act updates, wireless segments of eGOV projects, TD-SCDMA deployment strategy, and the upcoming State Communications Commission's (SCC's) new mission and organization.

Over 20 Fortune 500 industry leaders are gathering at GMC 2005 to help define China's future mobile communications technologies. Many of the world's most famous wireless experts and inventors are attending this prestigious R&D event as well (including Martin Cooper, Andrew Viterbi, and Norman Abramson).

Global Communications Newsletter

www.comsoc.org/pubs/gcn

NICOLAE OACA
Editor

Calea Mosilor No. 241
Bl. 47, Sc. 3, Ap. 71
Sector 2, Bucharest 020874
Romania
Tel: 00 40 766 505 784
Fax: 00 40 21 210 12 24
E-mail: nicolae_oaca@yahoo.com
gcn@comsoc.org

OCTAVIAN FRATU AND SIMONA HALUNGA, Associate Editors
Email:

octavian.fratu@elcom.pub.ro, simona.halunga@elcom.pub.ro
JACOB BAAL-SCHEM, Chapters Corner Editor

Regional Correspondents

HOSSAN AFI, France • BORHANUDIN MOHD ALI, MALAYSIA
JACOB BAAL-SCHEM, Israel • DINKO BEGUSIC, Croatia
OMAR CHERKAOU, CANADA • PAULO DE SOUSA, European Union
VOULA GEORGOPOULOS, Greece • SILVIA GIORDANO, Switzerland
RAM G. GUPTA, India • CARLOS HIRSCH, Mexico
MILAN JANKIVIC, SERBIA • LIANG XIONG JIAN, China
HENRICH S. LANTSBERG, RUSSIA • ARTUR LASON, Poland
JOSÉ MARIA MALGOSA-SANAHUJA, Spain • NICOLAE OACA, ROMANIA
IRADI OUYEYSI, AUSTRALIA • ALGIRDAS PAKSTAS, UK
GIANCARLO PIRANI, Italy • K. R. SUBRAMANIAN, Singapore
HELIO WALDMAN, Brazil



A publication of the
IEEE Communications Society